

Genelec 1032A
Bi-amplified Monitoring System



1032A Bi-amplified Active Monitoring System



APPLICATIONS

- Near Field Monitoring
- Broadcast Monitoring
- TV Control Rooms
- Mobile Vans
- Video Post Production
- Project Studios
- Digital Workstations

SYSTEM

The Genelec 1032A is a two-way active monitoring system including magnetically shielded loudspeaker drivers, speaker enclosure, multiple power amplifiers and active, low signal level crossover. Based on the famous 1031A near field monitor, the 1032A offers extended low frequency response and an increased maximum SPL. Due to its compact size, this system is ideal for high power near field monitoring. Furthermore, it is well suited to general purpose broadcasting applications, TV control rooms, mobile vans and CD mastering as well as home studios.

The unique Directivity Control Waveguide (DCW) Technology used provides excellent stereo imaging and frequency balance even in difficult acoustic environments. The fast, low distortion amplifiers are capable of driving the stereo system to peak output levels in

excess of 124 dB SPL at 1 m with program signals.

Versatile crossover controls allow for precise matching of the speaker system to different acoustic conditions. The system can be used in both vertical and horizontal orientation by simply rotating the DCW unit.

INTEGRATED CONSTRUCTION

The system is very easy to use as only mains power and input signal are needed. Uniform performance is obtained through the integration of the loudspeakers and amplifiers as a complete matched and calibrated package. The rugged amplifier is mounted into the enclosure with vibration isolators which also act as quick release hinges making maintenance operations very easy and straightforward. The speaker cabinet is constructed of veneered MDF, which is heavily braced to eliminate structural resonances.

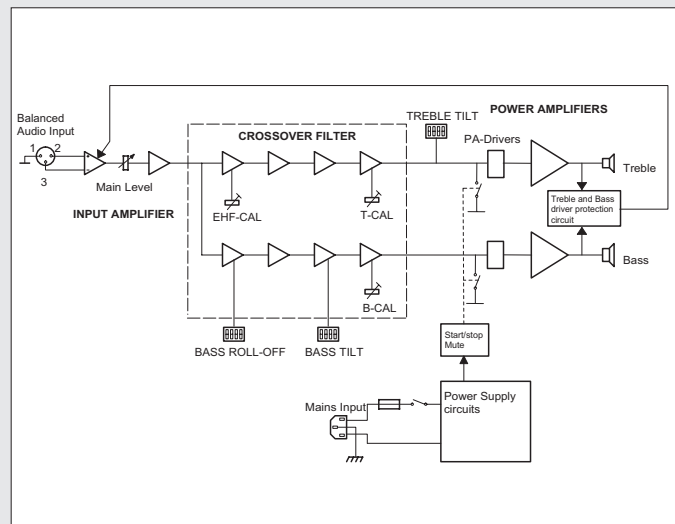

The block diagram showing active crossover filters, power amplifiers and driver units.



Two channel amplifier is housed in the speaker cabinet

AMPLIFIERS

The bass and treble amplifiers each produce 180 W and 120 W respectively of short term power with very low THD and IM distortion. Special attention has been paid to the electronic design to ensure the highest subjective sound quality currently possible. The system incorporates special circuitry for driver overload protection. Thermal protection is included for the amplifiers.



Horizontal mounting



Vertical mounting

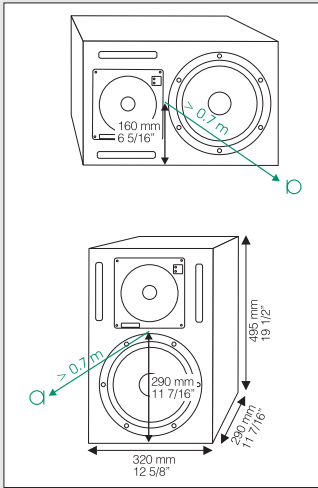

The reference axis lies between bass and tweeter drivers.

CROSSOVER FILTERS

The crossover frequency of the active crossover is 1.8 kHz. In order to obtain uniform frequency balance in differing acoustic conditions, special calibrated controls are included in the crossover. Three such controls are at the users disposition including treble and bass tilt, and bass roll-off switch. Each of these controls allow for adjustment in 2 dB increments and also provide the possibility of muting the channel for test purposes. A high pass filter is included in the LF channel to protect the woofer from subsonic signals. The crossover network is driven by an active balanced input stage. Variable input sensitivity allows for accurate level matching to the mixing console.

DRIVERS

The bass frequencies are reproduced by a 250 mm (10") bass driver loaded by a 24 litre vented box. The -3 dB point is 40 Hz and the low frequency response extends down to 36 Hz.

The high frequency driver is a 25 mm (1") metal dome, with pistonic behavior upto 23 kHz, is loaded by a proprietary DCW. Both drivers are magnetically shielded for applications where the stray magnetic field must be minimized.



Calibrated 'Tilt' switch. MUTE disconnects the channel for testing.

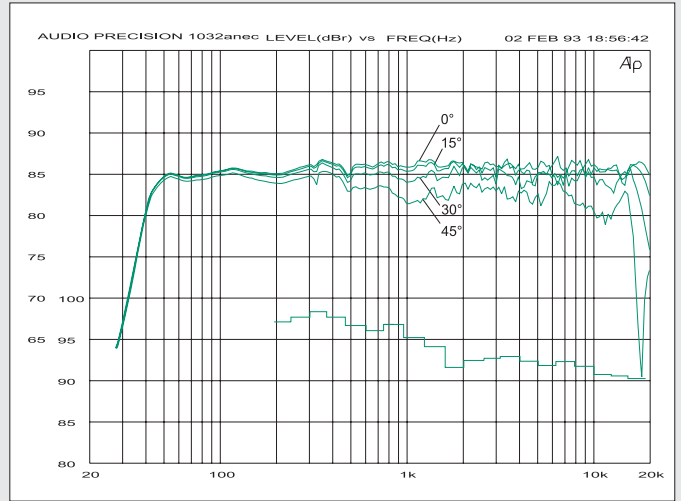

The upper curve group shows the horizontal directivity characteristics of the 1032A in its vertical configuration measured at 1 m. The lower curve is a 1/3 octave band power response, measured in an IEC approved reverberation chamber.

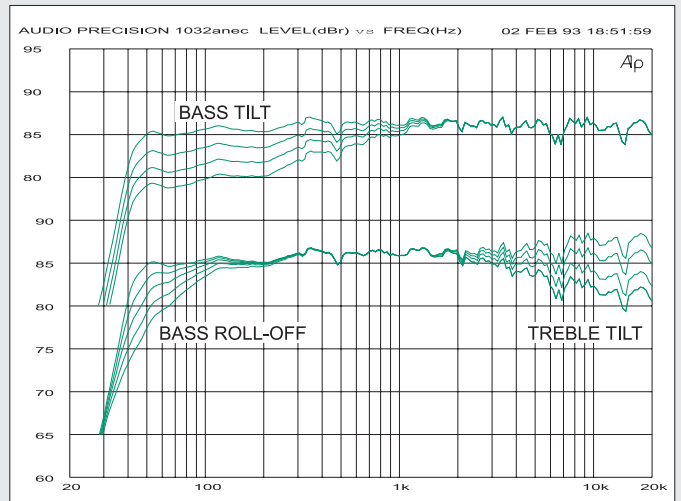

The upper curves show the effect of the 'bass tilt' control on the free field response. The lower curves show the effect of the 'treble tilt' and 'bass roll-off' controls.

DCWTECHNOLOGY

The revolutionary Directivity Control Waveguide Technology is a means of greatly improving the performance of a direct radiating multiway loudspeaker under normal listening conditions. The basic idea is to match the different drive units precisely, in terms of both frequency response and directivity. This will result in a smoother and virtually uncoloured off-axis system response. Also, due to improved directivity control, especially in the midrange frequencies, more direct sound and less early boundary reflections are received at the listening position. This gives improved stereo imaging and ensures the system is less sensitive to differing control room acoustics than any conventional direct radiator design. The DCW Technology improves the drive unit sensitivity by

+2 to +6 dB thus increasing the system maximum sound pressure level.



The tweeter driver is mounted in a DCW to match the dispersion characteristics to that of the bass driver. The DCW may be rotated for horizontal or vertical mounting.

Options



Opt-01
Flight case
Order Code
1032-401



Opt-09
Grille
Order Code
1032-409



Opt-04
Wall Mount
Order Code
1032-404-V
1032-404-H



Opt-05
Floor stand
Order Code
1032-405-V
1032-405-H

SYSTEM SPECIFICATIONS

Lower cut-off frequency, -3 dB: ≤ 40 Hz
Upper cut-off frequency, -3 dB: ≥ 22 kHz

Free field frequency response of system:
42 Hz - 21 kHz (± 2.5 dB)

Maximum short term sine wave acoustic output on axis in half space, averaged from 100 Hz to 3 kHz:

@ 1m	≥ 113 dB SPL
@ 0.5m	≥ 119 dB SPL

Maximum long term RMS acoustic output in same conditions with IEC weighted noise (limited by driver unit protection circuit):

@ 1m	≥ 103 dB SPL
@ 0.5m	≥ 109 dB SPL

Maximum peak acoustic output per pair on top of console, @ 1 m from the engineer with music material: ≥ 124 dB

Self generated noise level in free field @ 1m on axis: ≤ 10 dB (A)

Harmonic distortion at 90 dB SPL @ 1m on axis:

Freq:	50...100 Hz	< 1%
	> 100 Hz	< 0.5%

Drivers:

Bass	250 mm (10") cone
Treble	25 mm (1") metal dome
Both drivers are magnetically shielded	

Weight: 21,7 kg (48 lb)

Dimensions:

Height	495 mm (19 1/2")
Width	320 mm (12 5/8")
Depth	290 mm (11 7/16")

AMPLIFIER SECTION

Bass amplifier output power with an 4 Ohm load: 180 W

Treble amplifier output power with an 8 Ohm load: 120 W

Long term output power is limited by driver unit protection circuitry.

Slew rate: 80 V/ μ s

Amplifier system distortion at nominal output:

THD	$\leq 0.05\%$
SMPTE-IM	$\leq 0.05\%$
CCIF-IM	$\leq 0.05\%$
DIM 100	$\leq 0.05\%$

Signal to Noise ratio, referred to full output:

Bass	≥ 100 dB
Treble	≥ 100 dB

Mains voltage: 100/200 V or 115/230 V

Voltage operating range nominal $\pm 10\%$

Power consumption:

Idle	50 W
Full output	200 W

CROSSOVER SECTION

Input connector: XLR female

pin 1	gnd
pin 2	+
pin 3	-

Input impedance: 10 kOhm balanced

Input level for 100 dB SPL output @ 1m: variable from +6 to -6 dBu

Input level for maximum short term output of 113 dB SPL @ 1m: variable from +19 to +7 dBu

Subsonic filter below 40 Hz : 18 dB/octave

Ultrasonic filter above 25 kHz: 12 dB/octave

Crossover frequency, Bass/Treble: 1.8 kHz

Crossover acoustical slopes: 24 - 32 dB/octave

Treble tilt control operating range in 2 dB steps: +2 to -4 dB & MUTE

Bass roll-off control operating range in 2 dB steps: 0 to -8 dB @ 40 Hz

Bass tilt control operating range in 2 dB steps: 0 to -6 dB & MUTE

The 'CAL' position is with all tone controls set to 'off' and input sensitivity control to maximum.

All data subject to change without prior notice